

## Filtro a Sabbia di Quarzite "SMF" (Sand Media Filter "SMF")

Il filtro a sabbia di quarzite monocamera viene impiegato per filtrare acqua proveniente da pozzo, lago, fiume, etc. con presenza di alghe, sostanze organiche, sabbia, argilla etc. In presenza di notevoli quantità di sabbia è consigliabile usare prima il separatore di sabbia. Accoppiare sempre un filtro a rete o a dischi in uscita.

(The one-chamber quartzite sand filter is suitable to filter water from a well, lake, river, etc. with the presence of algae, organic matter, sand, clay etc. In the presence of a considerable amount of suspended sand is advisable to use the hydrocyclone sand separator before. Pairing always a screen or disks filter output.)

<b>CORPO</b> (BODY)	In acciaio verniciato o zincato a caldo (painted steel or hot dip galvanized steel)
<b>ELEMENTO FILTRANTE</b> (FILTER ELEMENT)	Sabbia di Quarzite (1 – 2 mm) (Quartzite Sand (1 – 2 mm))
<b>PRESSIONE D'ESERCIZIO MASSIMA</b> (MAX WORKING PRESSURE)	8 bar

### PERDITE DI CARICO IN ZONA DI LAVORO SERIE SMF / T-0,5 (FLOW RESISTANCE IN WORK AREA SMF SERIES / T-0,5)

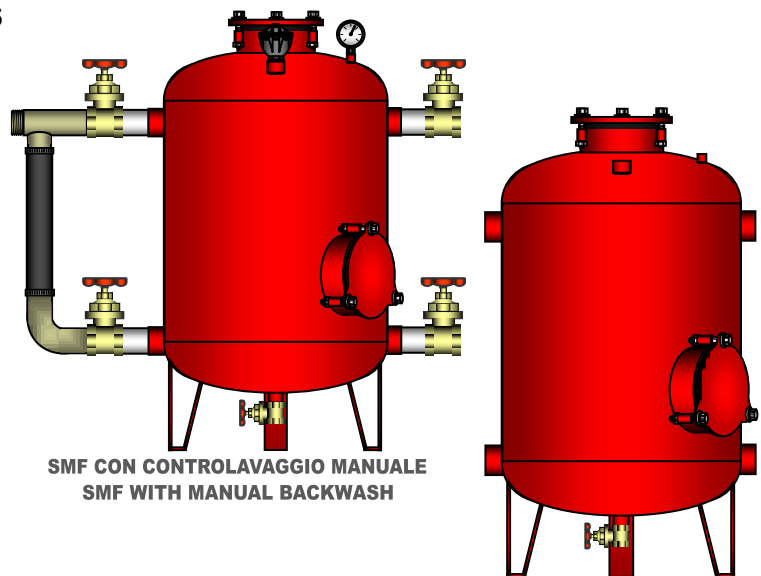
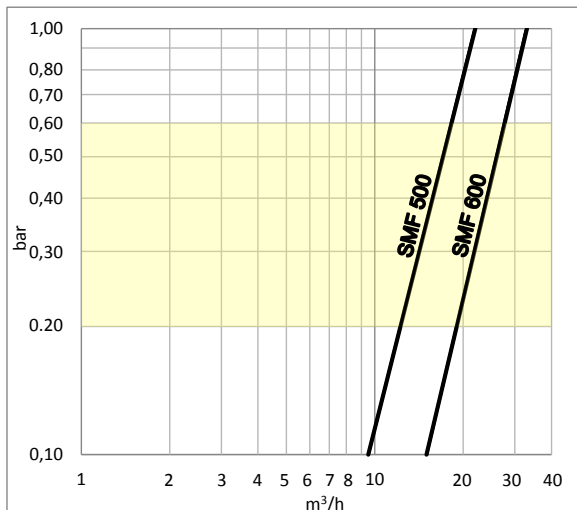

### PERDITE DI CARICO IN ZONA DI LAVORO SERIE SMF / D4.15-0,25 (FLOW RESISTANCE IN WORK AREA SMF SERIES / D4.15-0,25)

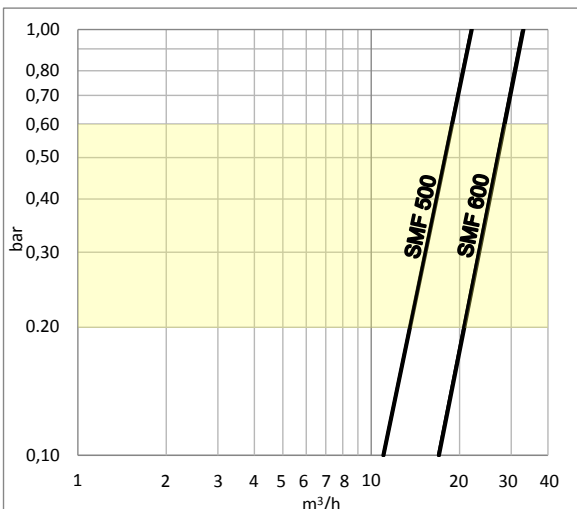

CARATTERISTICHE – characteristics						
Modello (Model) SMF	Ø In/Out (inch)	N° UGELLI nozzles nr.	PESO weight (kg)	PORTATA flow rate T-0,5 (m³/h)	PORTATA flow rate D4.15-0,25 (m³/h)	AREA FILTRANTE (filtration area) (cm²)
500	2"	15	55	9.5 – 22.5	11.5 – 22.5	1963
600	3"	21	70	15 – 32	17 – 32	2826

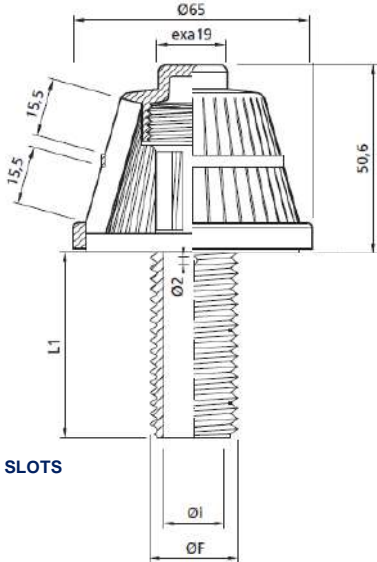

**UGELLI A FESSURE VERTICALI**  
**FILTER NOZZLE WITH VERTICAL SLOTS**

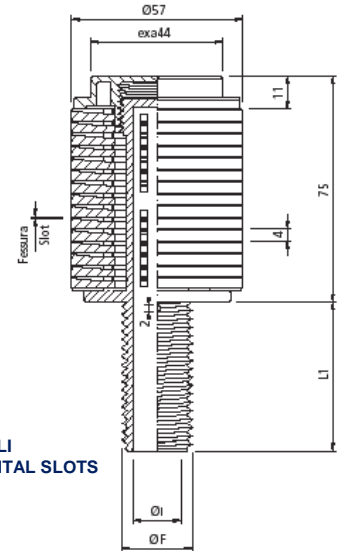

**UGELLI A FESSURE ORIZZONTALI**  
**FILTER NOZZLE WITH HORIZONTAL SLOTS**

Modello Model	Tipo Type	Fessura Slot width mm	N. Fessure Slots No.	Sezione Area mm <sup>2</sup>	Filetto Thread	ØF mm	ØI mm	Area codolo Stem area mm <sup>2</sup>	L1 mm
UGELLI A FESSURE VERTICALI FILTER NOZZLE WITH VERTICAL SLOTS	T	0,5	40	620	15/16"W	23,5	16	200	30
UGELLI A FESSURE ORIZZONTALI FILTER NOZZLE WITH HORIZONTAL SLOTS	D4.15	0,25	16	715	15/16"W	23,5	17	225	30

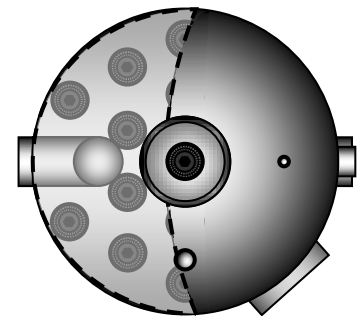
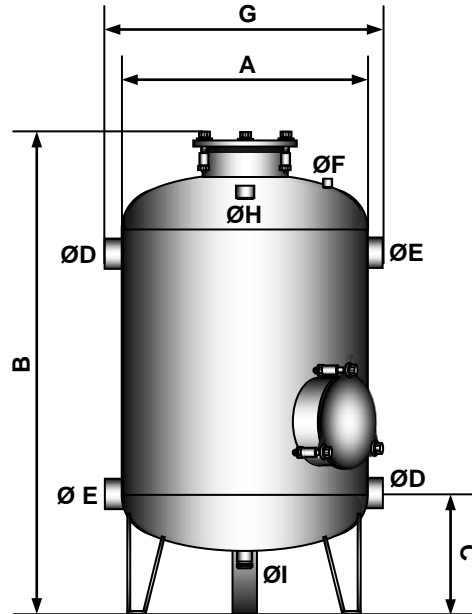
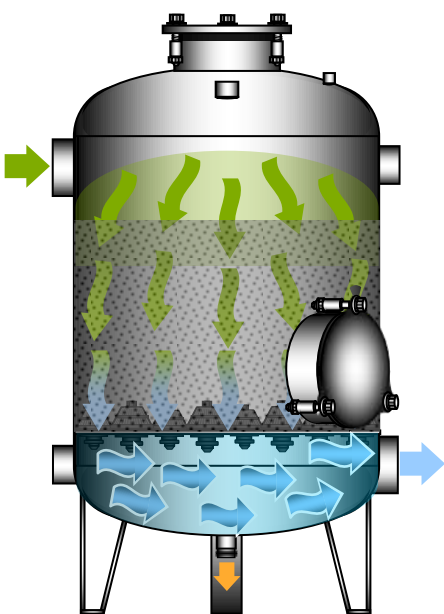

DIMENSIONI – dimensions		
<b>Modello (Model) SMF</b>	<b>500</b>	<b>600</b>
ØD (inch)	2"	3"
A (mm)	500	600
B (mm)	1100	1135
C (mm)	278	295
G (mm)	550	660
ØE (inch)	2"	2"
ØF (inch)	1/4"	1/4"
ØH (inch)	1"	1"
ØI (inch)	1"	1"
<b>SABBIA DI QUARZITE (quartzite sand) (kg)</b>	<b>150</b>	<b>200</b>
<b>IMBALLAGGIO (packaging) (m<sup>3</sup>)</b>	<b>0.35</b>	<b>0.50</b>