

Filtro a Sabbia di Quarzite "Lake" (Sand Media Filter "Lake")

Il filtro a sabbia di quarzite monocamera viene impiegato per filtrare acqua proveniente da pozzo, lago, fiume, etc. con presenza di alghe, sostanze organiche, sabbia, argilla etc. In presenza di notevoli quantità di sabbia è consigliabile usare prima il separatore di sabbia. Accoppiare sempre un filtro a rete o a dischi in uscita.

(The one-chamber quartzite sand filter is suitable to filter water from a well, lake, river, etc. with the presence of algae, organic matter, sand, clay etc. In the presence of a considerable amount of suspended sand is advisable to use the hydrocyclone sand separator before. Pairing always a screen or disks filter output.)

CORPO (BODY)	In acciaio verniciato o zincato a caldo (painted steel or hot dip galvanized steel)
ELEMENTO FILTRANTE (FILTER ELEMENT)	Sabbia di Quarzite (1 – 2 mm) (Quartzite Sand (1 – 2 mm))
PRESSIONE D'ESERCIZIO MASSIMA* (MAX WORKING PRESSURE*)	8 bar

PERDITE DI CARICO IN ZONA DI LAVORO SERIE LAKE / T-0,5 (FLOW RESISTANCE IN WORK AREA LAKE SERIES / T-0,5)

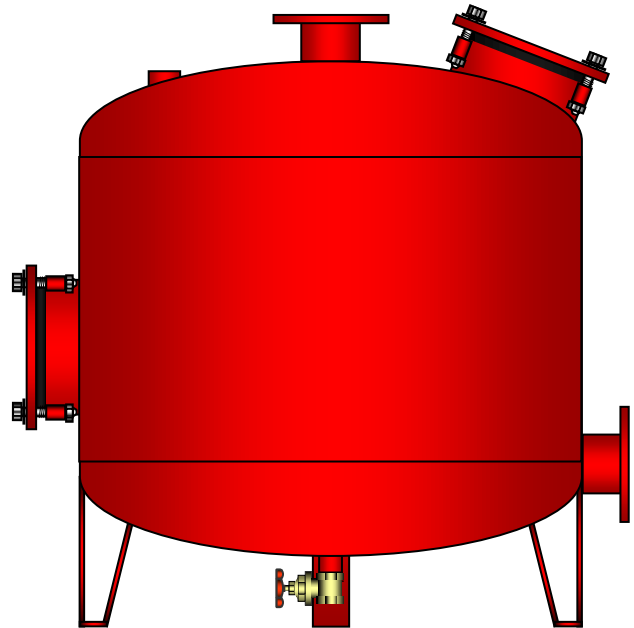
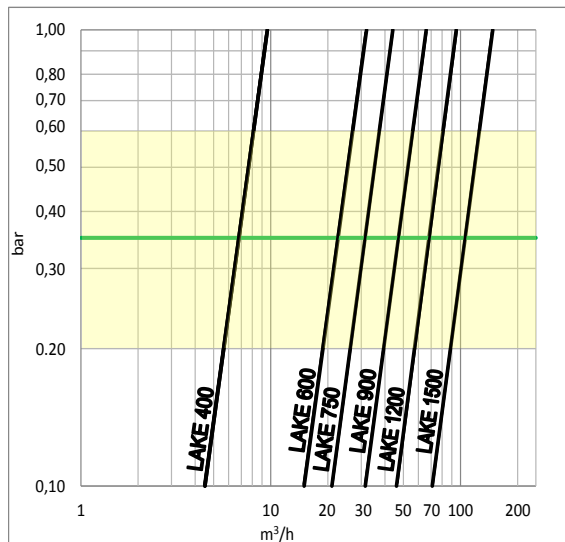

PERDITE DI CARICO IN ZONA DI LAVORO SERIE LAKE / D4.15-0,25 (FLOW RESISTANCE IN WORK AREA LAKE SERIES / D4.15-0,25)

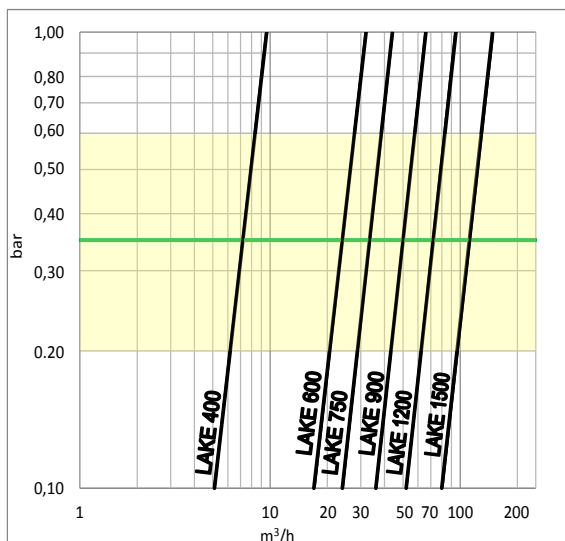

CARATTERISTICHE – characteristics						
Modello (Model) LAKE	Ø In/Out (inch)	N° UGELLI nozzles nr.	PESO weight (kg)	PORTATA flow rate T-0,5 (m³/h)	PORTATA flow rate D4.15-0,25 (m³/h)	AREA FILTRANTE (filtration area) (cm²)
400	1"	7	42	4.3 – 9.5	5.2 – 9.5	1256
600	2"	21	70	15 - 32	17 - 32	2826
750	3"	30	100	21 - 44	24 - 44	4416
900	3"	42	140	31.5 - 66	36 - 66	6359
1200	4"	65	240	46 - 95	52 - 95	11304
1500	4"	78	410	71 - 148	80 - 148	17662

Tutti i nostri filtri 'LAKE' sono sottoposti a stress-test fino a 15-20bar. All our 'LAKE' filters are subjected to stress-test up to 15-20bar.

*Per il modello 'LAKE' 1500, la pressione massima di esercizio è 5bar.
*For the model 'LAKE' 1500, the maximum operating pressure is 5bar.

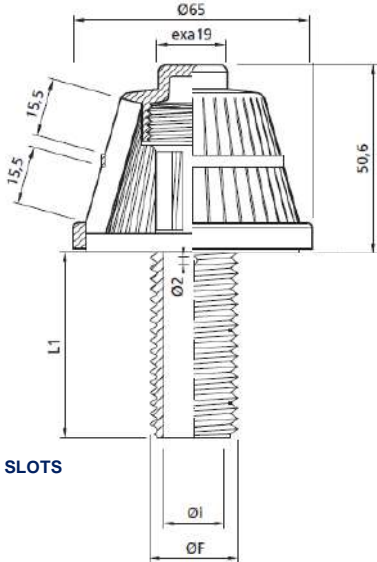

UGELLI A FESSURE VERTICALI
FILTER NOZZLE WITH VERTICAL SLOTS

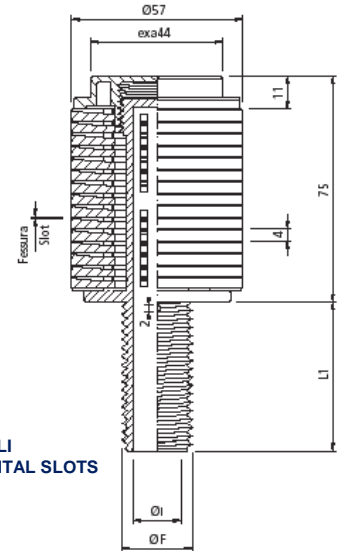

UGELLI A FESSURE ORIZZONTALI
FILTER NOZZLE WITH HORIZONTAL SLOTS

Modello Model	Tipo Type	Fessura Slot width mm	N. Fessure Slots No.	Sezione Area mm ²	Filetto Thread	ØF mm	ØI mm	Area codolo Stem area mm ²	L1 mm
UGELLI A FESSURE VERTICALI FILTER NOZZLE WITH VERTICAL SLOTS	T	0,5	40	620	15/16"W	23,5	16	200	30
UGELLI A FESSURE ORIZZONTALI FILTER NOZZLE WITH HORIZONTAL SLOTS	D4.15	0,25	16	715	15/16"W	23,5	17	225	30

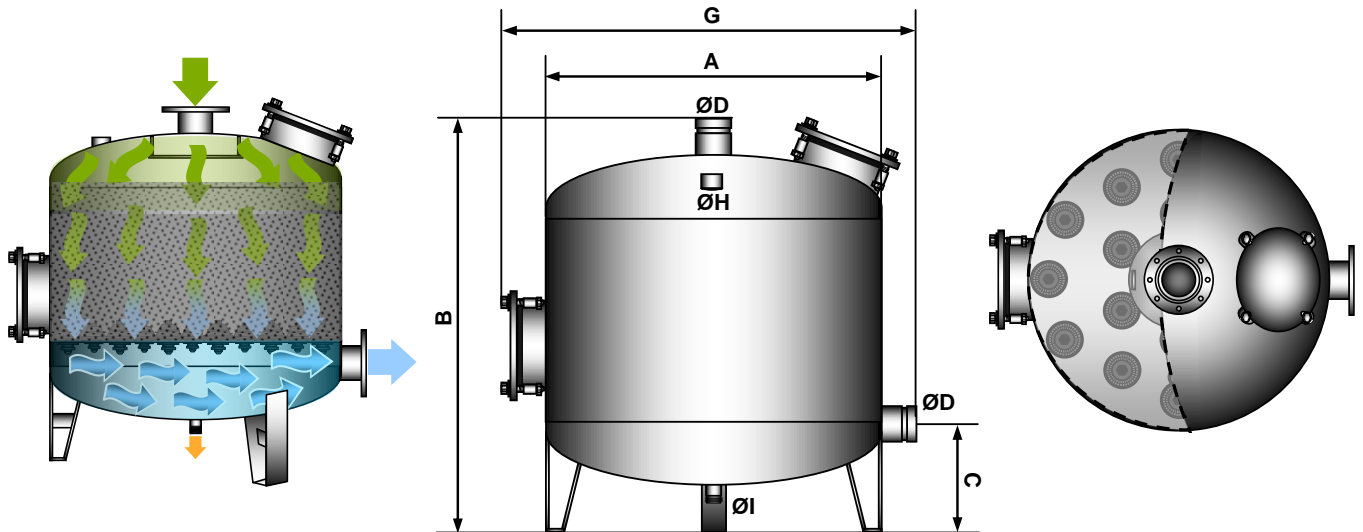

DIMENSIONI – dimensions

Modello (Model) LAKE	400	600	750	900	1200	1500
ØD (inch)	1"	VIC60	VIC80	DN80/VIC80	DN100	DN100
A (mm)	400	600	750	900	1200	1500
B (mm)	1035	1125	1220	1230	1410	1555
C (mm)	270	295	315	340	425	495
G (mm)	515	780	930	1080	1400	1700
ØH (inch)	1"	1"	1"	1"	1"	1"
ØI (inch)	1"	1"	1"	1"	1"	1"
SABBIA DI QUARZITE (quartzite sand) (kg)	100	200	350	500	800	1000
IMBALLAGGIO (packaging) (m ³)	0.30	0.70	1.05	1.40	2.70	4.55

Consigliamo una valvola sostegno pressione all'uscita delle stazioni filtranti!

We recommend a pressure sustaining valve to the outlet of filtration stations!